



**Esempi di efficientamento energetico nell'industria ceramica**  
**Examples of energy efficiency in the ceramic industry**

---

P r e s e n t a t i o n b y  
S t e f a n o O r l a n d i

# S U M M E R Y

- Recuperi di calore dal forno  
Heat from Kiln
- Recuperi di calore da Cogenerazione  
Heat from Co-generation

# ROLLER KILN ENERGY BALANCE

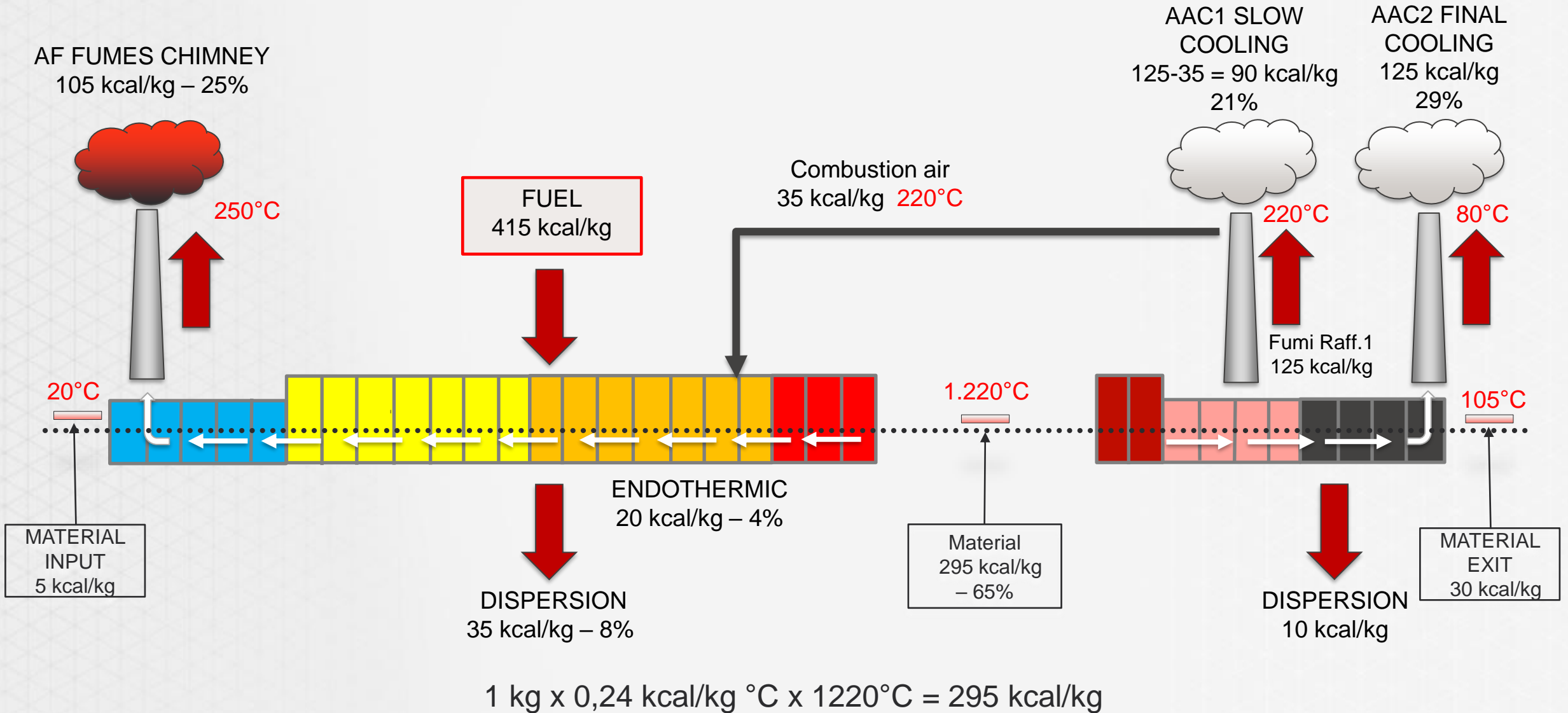

# HORIZONTAL DRYERS



# EVA



# SPRAY DRYER



# BUILDING HEATING



AAC1

AAC2

AAC1 + AAC2

# HEAT RECOVERY

## DRIER ZERO FUEL



It's possible to retrieve all the cooling air, including the air from the final cooling zone. In this regard, we have designed and developed solutions that provide air - in sufficient quantities and at the right temperature - to run a multi-level dryer at full capacity *without* fuel. We call this a “zero fuel dryer”.

# RECOVERY HEAT FOR ZERO FUEL DRIER





## RECOVERY HEAT FROM KILN CHIMNEY

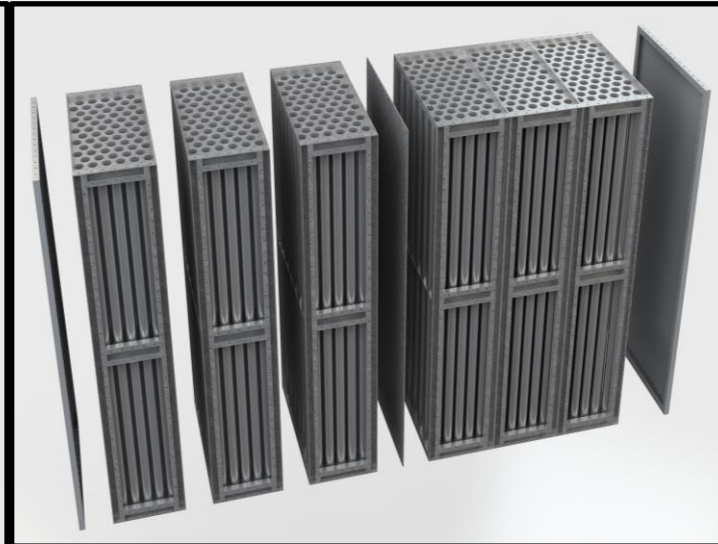

- ✓ High efficiency
- ✓ High flexibility to meet a range of market needs
- ✓ Highly automated operation within the production process
- ✓ Shorter delivery and assembly times

**HORIZONTAL DRYERS**



**EVA**



**HEAT EXCHANGER**

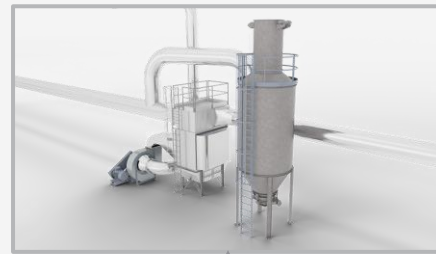

**SPRAY DRYER**

**EUP**

**KILN**

**BUILDING HEATING**



**HEAT RECOVERY**



# CO - GENERATION

CO-GENERATION means the simultaneous production of mechanical energy (transformed into electrical energy using an alternator machine) and heat (thermal energy).

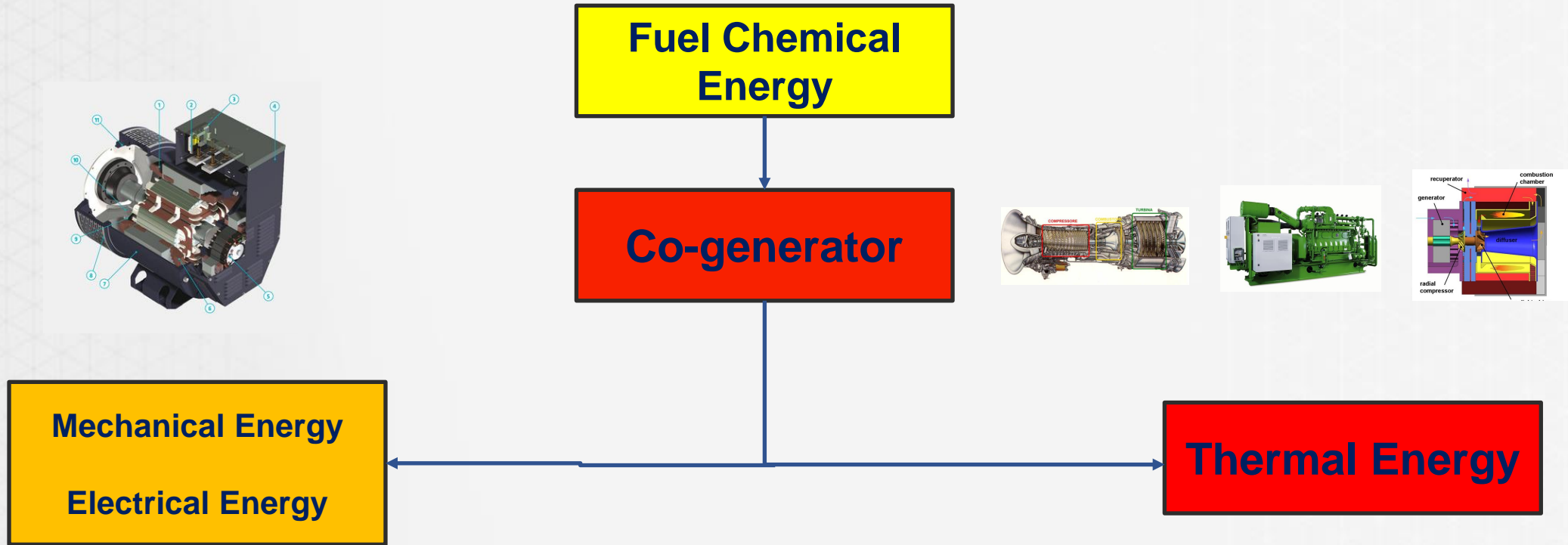

# CO-GENERATION: TURBINE- GAS ENGINE- MICROTURBINE

## TG –Gas Turbine >1 MWe

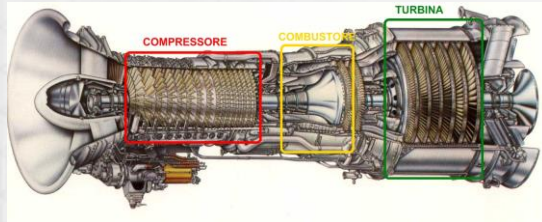

Electric efficiency  $\eta_e = 30 - 34\%$   
 Thermic efficiency  $\eta_t = 56 - 60\%$   
 Total lost  $\approx 10 - 12\%$

Fumes temperature:  $480^\circ - 550^\circ\text{C}$ ;  
 Low maintenance cost;  
 Low emission CO e NOx;

Continuous operation (low flexibility)  
 High investment costs

## MCI – Gas Engine From 1 to 6 MWe



Electric efficiency  $\eta_e = 40 - 44\%$   
 Thermic efficiency  $\eta_t = 46 - 50\%$   
 Total lost  $\approx 10\%$

Fumes temperature :  $390^\circ - 410^\circ\text{C}$  (ca. 50% termico)  
 Hot water  $95^\circ\text{C}$  ( ca. 50% del termico)  
 High operating flexibility

High maintenance cost  
 Management of hot water coming from the cooling banks

## MTG -Microturbine From 30 to 300 kWe

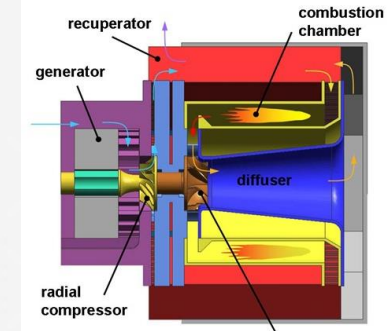

Electric efficiency  $\eta_e = 30\%$   
 Thermic efficiency  $\eta_t = 55 - 58\%$   
 Total lost  $\approx 12 - 15\%$

Fumes temperature :  $270 - 300^\circ\text{C}$   
 High flexibility operation through modular groups;  
 Small size  
 Low emission CO e NOx;

High investment costs  
 High speed rotation



# CO-GENERATION: TURBINE



TO SPRAY DRYER

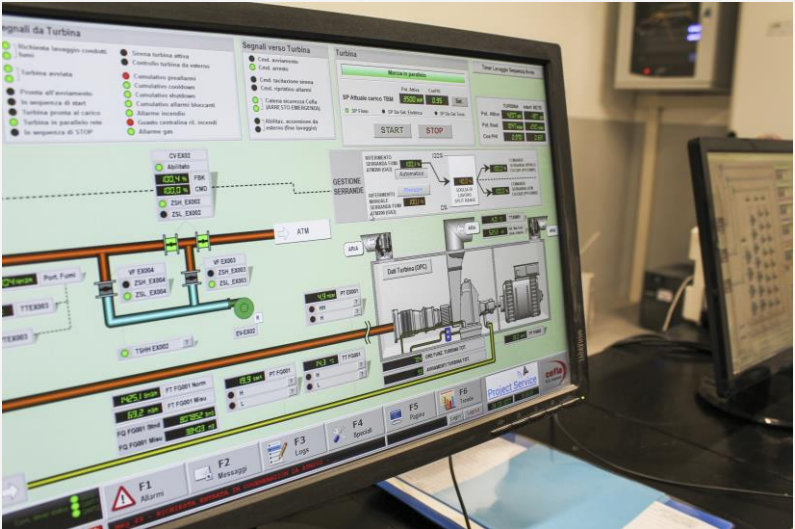

# CO-GENERATION: GAS ENGINE





# CO-GENERATION: APPLICATION

WATER/AIR EXCHANGER

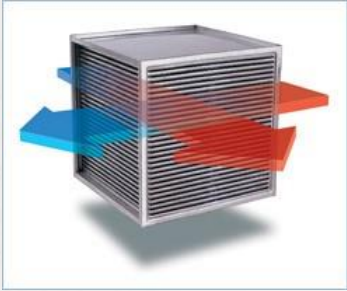

HOT AIR



SPRAY DRYER



EVA



WATER/WATER EXCHANGER

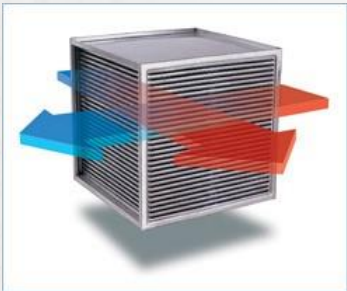

HOT WATER 65°C



MILL

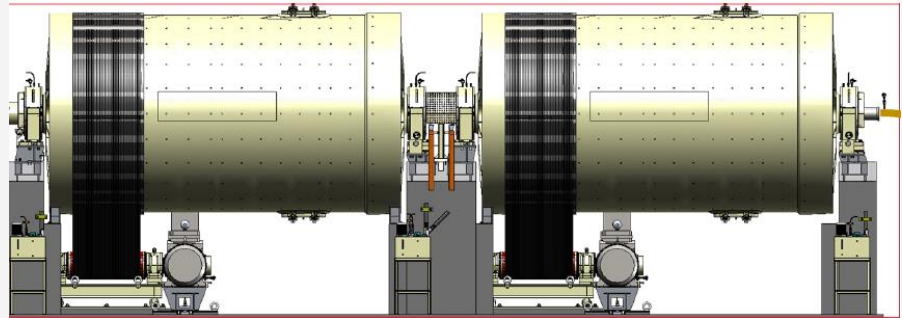

SPIRAL EXCHANGER

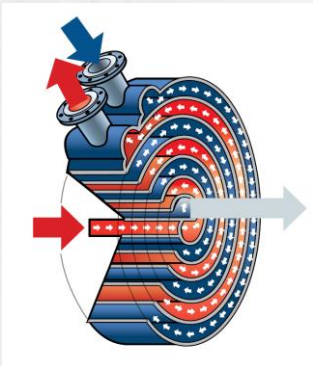

HOT SLIP 75°C



SPRAY DRYER





# TRI - GENERATION

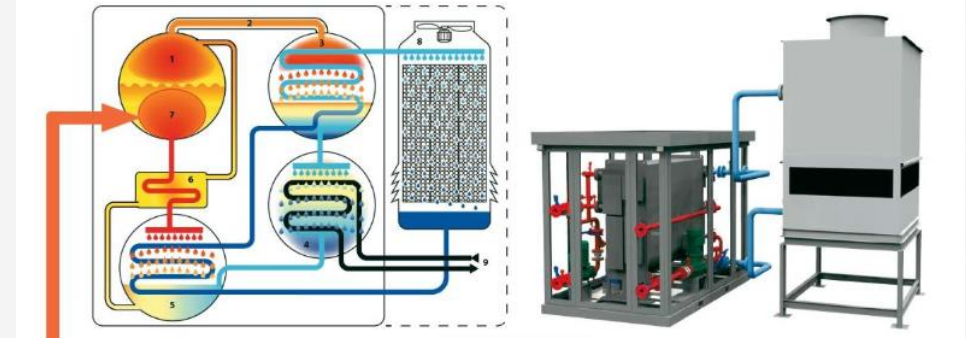
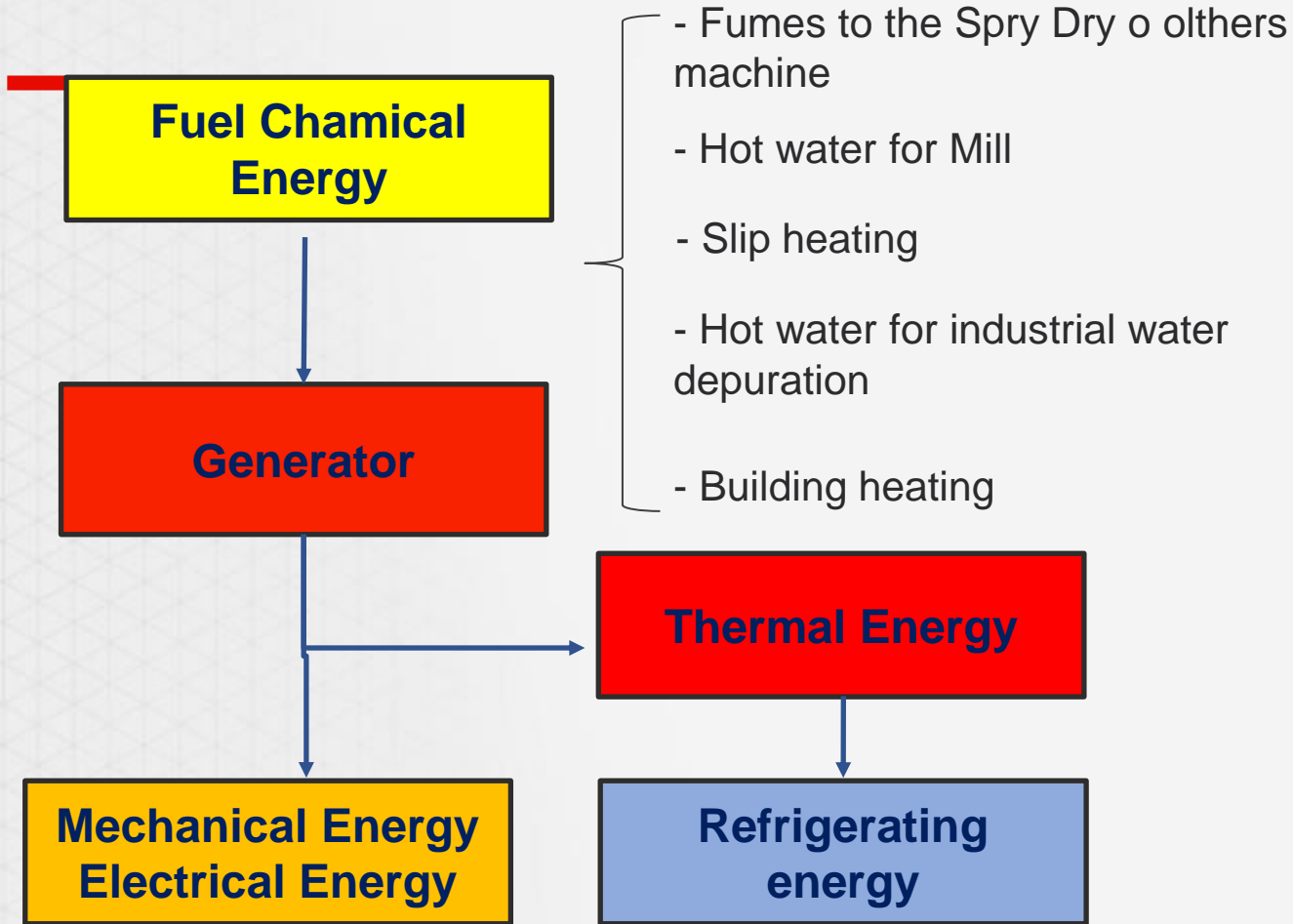

- Cool press oil
- Cooling of tiles before digital decorations
- Building conditioning



**SACMI**

THANK YOU FOR YOUR KIND ATTENTION

Stefano Orlandi

[stefano.orlandi@sacmigroup.com](mailto:stefano.orlandi@sacmigroup.com)